

MULTIFUNCTIONAL DISPLAY MODULE MOD 20

Anzeigemodule mit programmierbaren Ein- und Ausgängen für absolute Winkelcodierer mit SSI-Schnittstelle und inkrementale Drehgeber

Module avec sortie programmer par Codeur optique absolu avec SSI-interface et Codeurs optiques incrementaux

Display with programmable inputs and outputs for Absolut-Encoder with SSI interface and Incremental Encoder



MOD 20 - a programmable multifunctional display module alternatively for one absolute single- or multi-turn encoder with SSI or parallel interface and a resolution up to 30 bit or one incremental encoder. Display parameters are fully programmable. MOD 20 has the usual standard function of a display module, but additional 9 control outputs, which can be programmed separately by 24 cam switches as comparator, cam switch or pulse switch. Easy programming by four front-panel keys or by PC with RS232 interface.

SSI-Interface

For operation of one absolute single- or multi-turn-encoders with resolution up to 30 bit with serial SSI-Interface.

Incremental-Input

For operation of one incremental encoder with 3 or 6 output channels, RS422 linedriver or push-pull outputs. Optically insulated with optocoupler.

Display-Scaling

Scale factor, adjustment values and counting direction are free programmable.

Programmable Control-Inputs

6 optically insulated control-inputs are programmable for various functions, e.g. storing of display data or enable of counter.

Programmable Control-Outputs

9 optically insulated control-outputs, which can be programmed separately by 24 cam switches as a comparator, cam switch or pulse switch.

The cycle time is only 250 µs.

Analogue-Output

1 optically insulated programmable analogue-output, which can be used as voltage or current output. High precision D/A-converter with 16 bit resolution.

Parallel-Interface

Optically insulated input for operation of one absolute encoder with parallel output. Optically insulated output for data output of position data or velocity data in binary, gray or BCD code.

Serial Interfaces

RS232C One display module can be connected to a PC for programming and reading data.

RS422/485 Up to 31 display modules can be connected to a PC.

CANBUS Up to 32 display modules can be connected with CANBUS.

Product description MOD 20

SSI-Interface							
Incremental-Input							
Display-Scaling							
Programmable Control-Inputs							
Programmable Control-Outputs							
Serial Interfaces							
Analogue-Output							
Parallel-Interface							
MOD 20- 1			●	●	●	●	●
MOD 20- 2		●	●	●	●	●	●
MOD 20- 3	●		●	●	●	●	●
MOD 20- 4	●	●	●	●	●	●	●

ZE617-510
Änderungen vorbehalten / Subject to change

Technical data

Supply voltage	+10 ... 35 VDC
Power consumption	<150 mA (without load)
Cycle time	250 µs
Display range	-9999999 ... 99999999
Display	8 digit 7-segment red LED 14 mm high
Data memory	EEPROM
Operating temperature	0 ... +50°C
Connections	Terminal block, max. 1,5 mm ² Sub-D-connector
Weight	< 0,7 kg
Protection	front IP 50 with protective cover IP 54 rear IP 20

SSI-Interface

Clock frequency	125 kHz and 139 kHz
Clock output	RS422
Clock input	Optocoupler RS485

Incremental-Input

Circuit	Optocoupler
Input level 5 VDC	high +2,8...+5 VDC low 0...+0,8 VDC
Input level 24 VDC	high +12...+35 VDC low 0...+5 VDC
Input resistance	3 kΩ at 24 V / 350 Ω at 5V
Input frequency	max. 150 kHz
Pulse length channel M	min. 2 µs

Control-Inputs

Circuit	Optocoupler
Input level Low	0 ... +5 VDC
Input level High	+10 ... 35 VDC
Input resistance	1,8 kΩ at 24 VDC

Control-Outputs

Circuit	Optocoupler with NFET-driver
Supply voltage	max. +35 VDC
Output voltage	min. V _{cc} - 2 V at 50 mA
Output current	max. 500 mA, short-circuit proof

Analogue Voltage-Output

Voltage range	-10 ... +10 VDC
Resolution	305 µV = 16 Bit
Temperature stability	max. 20 ppm / °C
Output current	max. 12 mA, short-circuit proof

Analogue Current-Output

Current range	-20 ... +20 mA
Resolution	610 nA = 16 Bit
Temperature stability	max. 20 ppm / °C
Burden	max. 550 Ω

Parallel-Inputs

Circuit	Optocoupler
Input level Low	0 ... +5 VDC
Input level High	+10 ... 35 VDC
Input resistance	6,8 kΩ at 24 VDC

Parallel-Outputs

Circuit	Optocoupler, NPN-transistor open-emitter with PTC
Supply voltage	max. +35 VDC
Output voltage	min. V _{cc} - 3,5 V at 50 mA
Output current	max. 50 mA

Serial Interfaces

RS232C	Baudrate 9600 ... 57600 Bit/s
RS422/485	Baudrate 9600 ... 57600 Bit/s

CANBUS

Protocol	AP-Link
PDOs	1 Input, 1 Output, 64 Bit length
Baudrate	20 kBit/s up to 1MBit/s

Electrical connection diagram

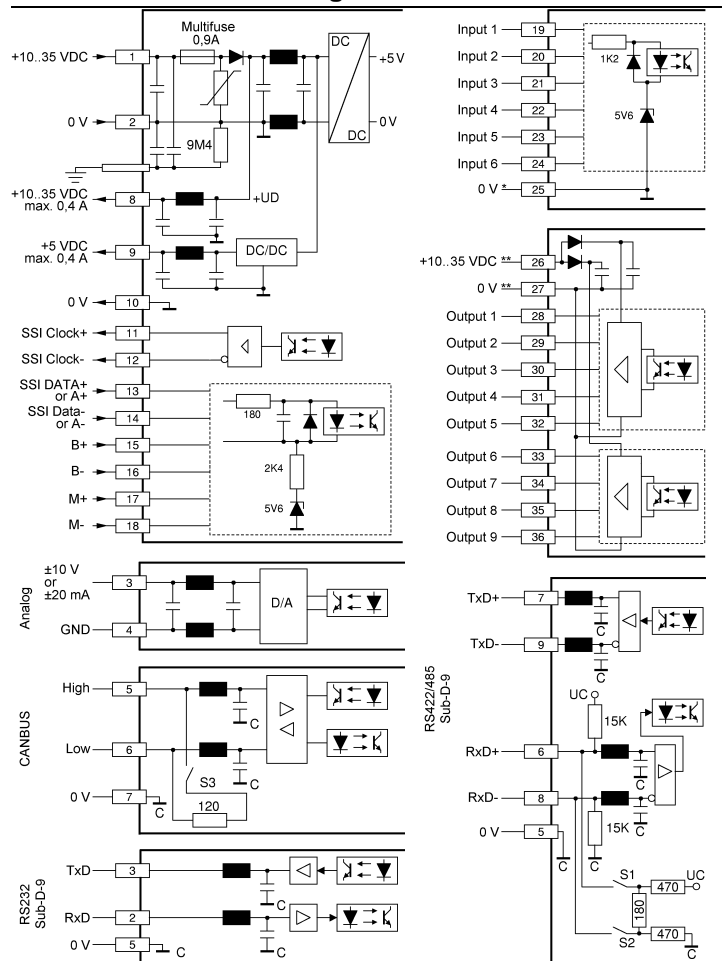

Electrical connection - Rear panel

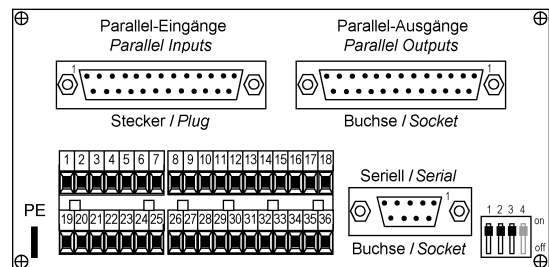

Outline drawing

